

User manual
10-2019
For framenumbers:
3601901xxx

 **EUROBOOR**
FOR PROFESSIONALS BY PROFESSIONALS

Cordless rail drilling machine

RAIL.360

Serial number:

Date of purchase:

Don't forget to register your machine at:

www.euroboor.com/register

[only when registered you benefit from extended warranty]

Congratulations on purchasing this premium rail drilling machine. At Euroboor we strive to exceed our customers' expectations by developing and providing premium and innovative portable drilling and cutting solutions. We believe that a professional like you must be able to rely on a professional supplier. Which has led us to become a major player in the industrial world, with our own factory and several offices worldwide. All because we have always listened to our customers and to the demands from the market.

Our vision is focused on developing innovative portable tools that add value for our customers and facilitate them in their daily work. We never lose sight of sustainability, time savings and cost savings.

Enjoy your new machine!

Before operating your new rail drilling machine, please first read all instructions. You find the instructions in this manual and on the warning label on your machine. With proper use, care and maintenance your machine will provide you with years of premium drilling performance.

TO REDUCE THE RISK OF INJURY USER MUST READ AND UNDERSTAND ALL INSTRUCTIONS

To view all our offices and their contact information please visit:

www.euroboor.com

Table of contents

Inhoudsopgave

1. Safety	4
1.1 General safety instructions.....	4
1.2 Specific safety information.....	6
2. Description	7
2.1 Intended use.....	7
2.2 Description and features.....	7
2.3 Box contents.....	8
2.4 Serial number.....	8
2.5 Technical data.....	8
2.6 Rail adapter.....	9
2.7 Symbols.....	10
2.8 Environmental.....	11
3. Preparation & adjustment	12
3.1 Assembly.....	12
3.2 Prior to use.....	13
4. Using the machine	14
2.1 Control panel.....	14
2.2 Spindle.....	15
2.3 Switching motor on and off.....	15
2.4 Safety rules 37V/2.6Ah lithium ion battery pack.....	16
2.5 Battery charger.....	19
5. Working with operation tools	20
5.1 Annular cutters.....	20
6. Maintenance	22
7. Trouble shooting	24
8. Exploded view & spare part list	25
2.1 Exploded views.....	25
2.2 Spare part lists.....	26
2.3 Exploded view & spare parts rail adapter.....	27
2.4 Wiring diagram.....	30

1. Safety

1.1 General safety instructions

Do not use this rail drilling machine before you have thoroughly read and completely understood this manual, specifically the “General safety instructions” and “Specific safety information” , including the figures, specifications, safety regulations and the signs indicating DANGER, WARNING and CAUTION.



WARNING: When using power tools basic safety precautions should always be followed to reduce the risk of fire, shock and personal injury.

Please also observe the relevant national industrial safety regulations. Non-observance of the safety instructions can lead to a shock, burns and/or severe injuries.

This manual should be kept for later use and enclosed with the rail drilling machine, should it be passed on or sold.

Work area

1. Keep your work area clean and well lit. Cluttered and dark work areas increase the change of accidents.
2. Do not operate a rail drilling machine in explosive atmospheres, such as in the presence of flammable liquids, gases or dust. A rail drilling machine may create sparks which could ignite the dust or fumes.
3. Keep bystanders, children and visitors away while operating a rail drilling machine. Distractions can cause you to lose control.

Personal safety

1. Stay alert, watch what you are doing and use common sense when using a rail drilling machine. Do not use the machine while tired or under the influence of drugs, alcohol, or medication. A moment of inattention while operating a rail drilling machine may result in serious personal injury.
2. Dress properly. Do not wear loose clothing or jewelry. Keep your hair, clothing and gloves away from moving parts. Loose clothes, jewelry, or long hair can be caught in moving parts.
3. Avoid accidental starting. Be sure the switch is off before plugging the machine in. Carrying a rail drilling machine with your finger on the switch or plugging in a rail drilling machine that has the switch on increases the change of accidents.
4. Never place hands, fingers, gloves or clothing near drilling area or rotating machine parts.
5. Remove adjusting keys or switches before turning the machine on. A wrench or a key that is left attached to a rotating part of the machine may result in personal injury.
6. Do not overreach. Keep proper footing and balance at all times. Proper footing and balance enables better control of the rail drilling machine in unexpected situations.
7. Use safety equipment. Always wear eye protection. Dust mask, non-skid safety shoes, hard hat and hearing protection must be used for optimal safety.

When using this machine, you MUST wear ear and eye protection.

Machine use and care

1. While operating the machine, the annular cutter must be cooled and lubricated
2. Always remove the slug from the annular cutter after each hole. **Caution;** the slug may be hot!
3. Do not use the machine when the switch does not turn it on or off. Any machine that cannot be controlled with the switch is dangerous and must be repaired.
4. Disconnect the plug from the power source before making any adjustments, changing accessories or storing the tool. Such preventive safety measures reduce the risk of starting the tool accidentally.
5. Store your rail drilling machine out of reach for children and other untrained persons. Tools are dangerous in the hands of untrained users.
6. Maintain your machine with care. Keep cutting tools sharp and clean. Properly maintained tools, with sharp cutting edges are less likely to break and are easier to control.
7. Check for misalignment of moving parts, breakage of parts and any other condition that may affect the machine's operation. If you detect damage have the machine serviced before use. Many accidents are caused by poorly maintained tools.
8. Only use accessories that are recommended by Euroboor for your machine model. Accessories that are suitable for one machine may become hazardous when used on another machine.

Service

1. Tool service must be performed only by qualified repair personnel. Service or maintenance performed by unqualified personnel could result in risk of injury.
2. When servicing a tool, use only identical replacement parts. Follow instructions in the maintenance section of this manual. Use of unauthorized parts or failure to follow maintenance instructions may create an injury.
3. Euroboor offers Armature kits containing official Euroboor spare parts suitable for your rail drilling machine.

1.2 Specific safety information

- Keep your fingers away from the drilling area;
- Avoid touching the slug that is automatically ejected by the pilot pin when the working procedure is finished. Contact with the slug when it is hot, or if it falls, can cause personal injuries;
- Do not switch on the machine before checking whether the stand has been tightened firmly to the mounting surface;
- Adjust the machine so cutter does not extend into the workpiece before drilling. Do not perform any design, assembly or construction activities on the workpiece while the machine is switched on;
- Before switching on the machine, make sure all accessories have been mounted correctly;
- Do not switch on the machine until it has been mounted and installed according to all above mentioned instructions;
- Always use the recommended speed for the accessories and material you are working with;
- Do not use the machine on the same workpiece on which electric welders are working;
- In case of a jammed cutter, turn off the machine, disconnect the machine from the power supply and then remove the reason for the jam before turning on the machine again.

Residual risk

In spite of following the relevant safety regulations and their implementation, certain residual risks cannot be avoided.

These are:

- Impairment of hearing
- Risk of personal injury from flying particles
- Risk of burns due to accessories becoming hot during operation
- Risk of personal injury due to prolonged use.

Always try to reduce these risks as much as possible.

2. Description

2.1 Intended use

This rail drilling machine is intended for commercial use as a drilling machine for drilling. Use always tools and accessories recommended by Euroboor.

2.2 Description and features



- 1. Feed Handle
- 2. Magnet Switch
- 3. Motor Switch
- 4. Rail Adapter

[image 1-1]

2.3 Case content

1 x RAIL.360 rail drilling machine

1 x battery pack 37 V / 2.6 Ah

1 x battery charger

3 x handles

1 x hex key 2.5 mm

1 x hex key 4 mm

1 x hex key 5 mm

1 x user manual

1 x safety ear protection

1 x safety goggles

1 x safety gloves

2.4 Serial number

The serial number is mentioned on the machine two times: engraved on the frame and on the serial no. sticker on the motor housing. Additional serial no. stickers are provided with the machine for your administration.

The serial number will help you, your dealer and Euroboor to validate and identify the machine.

For example:

3601909001

breaks down to:

360 19 09 001

Machine series

Year of manufacture

Month of manufacture

Identification number







2.5 Technical data

	Metric	Imperial
Annular cutting	Ø 12 - 36 mm	Ø 7/16" – 1 7/16"
Length	297 mm	11 11/16"
Width	125 mm	4 5/16"
Height	510 - 685 mm	20 1/16" – 27"
Stroke	230 mm	9 1/16"
Weight	16 kg	35.3 lbs
Battery	37 V / 2,6 Ah Li-ion	37 V / 2,6 Ah Li-ion
Charging time	0% to 75% - 17 minutes 75% to 100% - 58 minutes Fully charged - 75 minutes	
Speed (no load)	506 rpm	506 rpm
Speed (load 1300 W)	375 rpm	375 rpm
Spindle (Weldon)	19,05 mm	3/4"

2.6 Rail Adapter

The rail drilling machine is specifically designed for drilling in rails. The rail drilling machine is available in various versions, ensuring there is always the right rail adapter for the job. The rail adapter versions that we offer are: S49, S54, TR68, UIC50, UIC54 and UIC60.

2.7 Symbols

Symbol	Term, meaning	Explanation
	Read documentation	Be absolutely sure to read the documentation in this user manual and specifically the “General safety instructions” and “Specific safety information”.
	Wear ear protection	Use ear protection during operation.
	Wear eye protection	Use eye protection during operation.
	Danger/warning/caution	Read and apply the information in the adjacent text!
	European conformity symbol	Confirms the conformity of the rail drilling machine with the directives of the European Community.
	Class of protection I	Product with basic insulation and exposed (touchable) conductive parts additionally connected to the protective earth conductor.
mm	Millimeter	Unit of measurement for length, width, height or depth.
kg	Kilogram	Unit of measurement for the mass.
V	Volt	Unit of measurement for the electric voltage.
A	Ampere	Unit of measurement for the electric current intensity.
W	Watt	Unit of measurement for the output.
rpm	Revolutions per minute	Unit of measurement for the revolutions.
no	No load speed	Revolution speed at no load.

2.8 Environmental



Separate collection. This product must not be disposed of with normal household waste.



Separate collection of used products and packaging allows materials to be recycled and used again. Re-use of recycled materials helps prevent environmental pollution and reduces the demand for raw materials.

Local regulations may provide for separate collection of products from the household, at municipal waste sites or at the retailer when you purchase a new product.

3. Preparation & adjustment

3.1 Assembly



WARNING: To reduce the risk of injury, turn machine off before installing and removing accessories, before adjusting or changing set-ups or when making repairs. Be sure all switches are in the OFF position. An accidental start-up can cause injury.

Fitting the feed handles

1. Fit each of the three feed handles by screwing them into the hub in clockwise direction.
2. Tighten firmly by hand.

The handles are supposed to face slightly outward. Be careful not to cross-thread any of the components.

Battery pack

Charge the battery before use. If performance diminishes, recharge the battery pack. The ideal storage temperature is between 10° and 30°C.

Li-ion battery packs (37 V) have a capacity and signal display:

- Press button and the charge level is displayed by the LED lights;
- If red LED is displayed, the battery pack is almost flat and must be recharged;
- If all LED lights are flashing, the battery pack is too warm. Allow the battery pack to cool down.

Removing and inserting the battery pack

Removal

Press both buttons on the side of the battery pack and take out the battery from its position.

Inserting

Slide in the battery pack completely until it engages.

Removing and inserting an accessory



Remove the battery pack from the machine before any adjustments, conversions or servicing are performed.



If the tool is jammed: Press the RED switch "O" to switch off the motor unit. Then find out what is causing the machine to jam. Watch out : the annular cutter might be hot.

The tool holder accepts annular cutters with a 19,05 mm (3/4") Weldon shank with one or more flats.



WARNING: The teeth of a cutter are very sharp and can be dangerous.

1. Insert the shank of the accessory as far into the tool holder as possible;
2. Tighten the two allen screws with allen key;
3. To remove the accessory, loosen the allen screws and take out the accessory.

3.2 Prior to use

Check the machine for possible damage; Before using the machine, you must carefully check the protective components or slightly damaged components to ensure they are operating perfectly and as intended.

Check that moving parts are in perfect working order, do not jam and check whether the parts are damaged. All parts must be correctly installed and fulfill all conditions necessary to ensure perfect operation of the machine.

Damaged protective components must be repaired or replaced according to specifications by Euroboor or any authorized Euroboor dealer.

DO NOT use under wet conditions or in presence of flammable liquids or gases.

DO NOT let children come into contact with the machine. Supervision is required when inexperienced operators use this machine.

Useful tips

- Try a few simple projects using old rails until you develop a ‘feel’ for the rail drilling machine
- Let the machine run in for a period of eight to ten hours before starting with big operations
Do not load the machine too much during this run-in period.
- Never use the machine with serious overload
- Keep the machine clear from moisture at all times to protect the machine, yourself and others

4. Using the machine



WARNING: Always observe the safety instructions and applicable regulations.



WARNING: To reduce the risk of serious personal injury, turn the machine off before making any adjustments or removing/installing attachments or accessories.

4.1 Control panel

The control panel

The control panel on your rail drilling machine is designed for maximum ease of use and safety.

1 - The ON Switch (GREEN):

This (upper) switch is used to switch the motor unit On (“I”);

2 – The OFF Switch (RED)

This (lower) switch is used to switch the motor unit Off (“O”);

3 - The Magnet Switch (WHITE):

This switch is used to turn on the main power on or off.

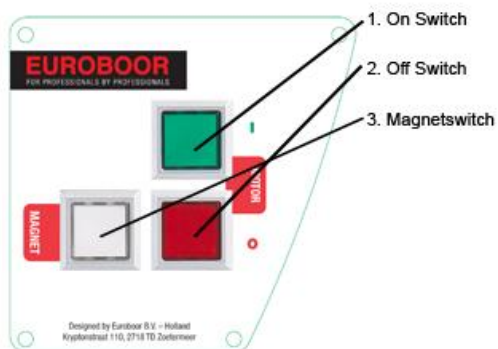

[image 2-2]

In order to operate properly, the machine has to be turned on following the procedure as described below.

Activating the machine

Connect the machine to the work piece. To activate the machine, press de WHITE switch (image. 2-2). To deactivate the machine, press the same button again.

Turning the motor on and off

The motor can only be switched on when the magnet switch is activated. To turn ON the motor, press the GREEN button “I”, the WHITE magnet switch will be lit yellow. To turn OFF the motor, press the RED button “O”.

4.2 Spindle

This machine is equipped with a detachable spindle drive with 19,05 mm (3/4")Weldon connection. To accommodate a drill chuck, either directly to the gearbox output shaft or with an adapter, the spindle can be detached.

1. Hold the gearbox output shaft in place with a narrow 18 mm spanner;
2. Loosen the spindle from the gearbox output shaft in counterclockwise direction with a 22 mm spanner at the top of the spindle;
3. Gently pull the spindle through the coolant ring and spindle holder, while holding the coolant ring in place;
4. You are now able to attach an adapter, drill chuck or different accessory to the gearbox output shaft. The thread specification is 1/2" x 20 UNF.

To reattach the spindle, follow above steps in reverse order. Make sure all parts are correctly aligned and firmly tightened.

4.3 Switching motor on and off

The motor unit can only be switched ON when the magnet switch is activated. Although it is a rail drilling machine, there is a magnet switch. The machine is in fact a converted magnetic drilling machine. To switch the motor ON, press the green button with marking "I". To switch the motor OFF, press the red button with marking "O".

4.4 Safety rules 37 V/ 2.6 Ah lithium -ion battery pack

Read all instructions. Failure to follow all instructions listed below may result in shock, fire and/or serious injury.

- Remove the battery pack from the machine before any adjustments, conversions or servicing are performed.
- Before fitting the battery pack, make sure that the machine is switched off.
- Do not open the battery pack.
- Do not place the battery pack on or near fires, heaters, other high temperature Locations or apply heat to the battery.
- Do not pierce the battery with any sharp objects, strike the battery with a hammer, tools, or heavy objects, step on the battery pack or otherwise damage the outer casing.
- Do not subject the battery pack to strong impacts or shocks.
- Do not expose the battery to water or any other type of liquid, or allow the battery to get wet.
- Do not leave the battery in direct sunlight, and avoid storing spare battery packs inside cars in extremely hot weather. Doing so may cause the battery to generate heat, rupture or ignite.

Using the battery in this manner may also result in a loss of performance and a shortened life expectancy. When a battery becomes too hot, the built-in protection circuitry is activated, preventing the battery from charging further. Heating the battery can destroy the safety devices, and can cause additional heating, rupture or ignition of the battery cells.

- Never short-circuit, reverse polarity, disassemble, damage or heat the battery pack over 100°C (212°F).
- If an exposed lithium-ion battery does start a fire , it may burn even more violently if it comes into contact with water or even the moisture in the air. **Do not throw water on a burning lithium battery!** A class C fire extinguisher must be used.
- Do not use the battery pack if the battery pack casing is broken or if a battery pack emits an unusual odor, smoke, excessive heat or leaks any substance. Avoid contact with any substance leaking from the battery pack.
- Keep out of reach from children and pets. Exposure to battery pack voltage could result in death or serious injury.
- The cells within the battery pack contain toxic substances. Do not attempt to open battery packs. Do not insert any object into the battery packs or use any device to pry at the battery pack casing. If you insert an object into any of the battery packs' ports or openings you could suffer shock, injury, burns or cause a fire. Attempting to open the battery pack casing will damage the casing and could release toxic and harmful substances, and will render the pack unusable.
- If battery fluid leaks out and comes into contact with your skin, rinse immediately with plenty of water. If battery fluid leaks out and comes into contact with your eyes, wash them with clean water and seek medical attention immediately.
- As with all rechargeable batteries, do not charge near flammable materials.
- Do not disassemble or modify the battery pack . The battery contains safety and protection devices which, if damaged, may cause the battery to generate heat, rupture or ignite.
- Any modification may damage the battery pack or cells and will invalidate any warranty claim.
- If you happen to get any electrolyte from the cells on your skin, wash thoroughly with soap and water. If in your eyes, do not rub. Rinse thoroughly with water and seek medical attention immediately.



CAUTION: *If at any point during the charging process none of the LEDs are lit, remove the battery pack from the charger to avoid damaging the product. Do not insert another battery. Return the charger and battery to your nearest service center for service or replacement.*



CAUTION: *Charge in a well ventilated area. Do not block charger vents. Keep them clear to allow proper ventilation.*

Battery protection features

Euroboor 37 V / 2.6 Ah lithium-ion batteries are designed with features that protect the lithium-ion cells and maximize battery life. Under some operating conditions, these built-in features may cause the battery and rail drilling machine to act differently from nickel-cadmium batteries.

During some applications, the battery electronics may signal the battery to shut down and cause the tool to stop running. To reset the battery and tool, release the trigger and resume normal operation.

NOTE: To prevent further shut down of the battery, avoid forcing the tool. Switching to a lower speed will also prevent shut down.

If releasing the trigger does not reset the battery and tool, the battery pack is depleted. If depleted, the battery pack will begin charging when placed on the lithium-ion charger.

To charge

A fully discharged battery pack with a temperature between 0° (32°F) and 65° (150°F) will charge in about an hour.

- Use battery pack only with the recommended Euroboor charger.
- Connect the charger to a power supply. Make sure the power supply is normal household voltage, **220 volts, AC only, 60 Hz.**
- Attach the battery pack to the charger by aligning the raised ribs on the battery pack with the grooves in the charger, then slide the battery pack onto the charger.
- Do not place the charger and battery pack in an area of extreme heat or cold. They will work best at normal room temperature.

NOTE: The charger and battery pack should be placed in a location where the temperature is more than 10° (50°F) but less than 38° (100°F).

- The battery pack will become slightly warm to the touch while charging. This is normal and does not indicate a problem.
- After charging is complete, the green LED will remain on until the battery pack is removed from the charger or charger is disconnected from the power supply.
- When batteries become fully charged, unplug the charger from the power supply and remove the battery pack.

Charging a hot battery pack

If the battery pack is above normal temperature range, the red LED will begin flashing and the green LED will be off. When the battery pack cools down to approximately 150°F, the charger will automatically begin charging again.

Charging a cool battery pack

If the battery pack is below normal temperature range, the red LED will begin flashing and the green LED will be off. When the battery warms to a temperature of more than 32°F, the charger will automatically begin charging again.

Cold weather operation

The lithium-ion battery pack can be used in temperatures down to -4°F. Put the battery pack on the rail drilling machine and use the tool in a light duty application. After about a minute, the pack will have warmed up and begin operating normally.

Maintenance

This battery pack is equipped with lithium-ion rechargeable batteries. Length of service from each charging will depend on the type of work you are doing.

These batteries have been designed to last as long as possible. However, like all batteries, they will eventually wear out. Do not disassemble battery pack and attempt to replace the batteries. Handling of these batteries, especially when wearing rings and jewelry, could result in a serious burn.

To obtain the longest possible battery life from Euroboor lithium-ion batteries, we suggest the following:

- Remove the battery pack from the charger once it is fully charged and ready for use.

For battery pack storage longer than 30 days:

- Store the battery pack where the temperature is below 80°F and away from moisture.
- Store battery packs in a 30%-50% charged condition.
- Every six months of storage, charge the pack as normal.

Battery pack removal and preparation for recycling

To preserve natural resources, please recycle or dispose of batteries properly.

This product contains lithium-ion batteries. Local, state or federal laws may prohibit disposal of lithium-ion batteries in ordinary trash.

Consult your local waste authority for information regarding available recycling and/or disposal options.

**WARNING:**

Upon removal, cover the battery pack's terminals with heavy-duty adhesive tape. Do not attempt to destroy or disassemble battery pack or remove any of its components. Lithium-ion batteries must be recycled or disposed of properly. Also, never touch both terminals with metal objects and/or body parts as short circuit may result. Keep away from children. Failure to comply with these warnings could result in fire and/or serious injury.

4.7 Battery charger

Charging the battery

On the battery charger there are two lights; RED and GREEN.

When the RED light flashes the battery is charged between 2% - 80%. When the GREEN light flashes the last 20% of the battery is charged.

When the green light stops flashing and remains lit green, the battery is fully charged and ready for use.



CAUTION: When both the RED and GREEN light are simultaneously lit than either the battery charger or the battery itself is too hot. If the RED and GREEN light on the charger are alternately flashing RED/GREEN, there is a general error.

Battery charging temperature protection

If the battery reaches 50°C, the charger will stop charging. Error signals: the RED and GREEN light are simultaneously lit RED and GREEN. The charger will start charging again if the temperature of the battery is 45°C or less.

Signals on the machine

Signals well-functioning rail drilling machine

- When the RAIL.360 rail drilling machine is well positioned on the work piece, press the magnet (white) switch to turn on the machine. The LED will flash GREEN two times and then remain GREEN.
- When the motor is switched on (green switch), the magnet switch will be lit yellow.

Signaling malfunctioning of the rail drilling machine

- When the (white) magnet switch is flashing RED, the battery is low.
- When the (white) magnet switch is flashing YELLOW, there is over current and the motor will stop.

5. Working with drilling accessories

5.1 Annular cutters

Annular cutters only cut material at the periphery of the hole, rather than converting the entire hole to shavings. As a result, the energy required to make a hole is lower than for a twist drill. When drilling with an annular cutter, it is not necessary to drill a pilot hole.

 **WARNING:** Do not touch the cutter or the parts close to the cutter immediately after operation, as they may be extremely hot and cause burns to the skin. Ensure nobody is in the work area where the metal core (slug) is ejected.

Drilling conditions

The ease with which material can be drilled depends on several factors including tensile strength and abrasion resistance. Whilst hardness and/or strength is the usual criterion, wide variations in machinability can exist among material showing similar physical properties.

The drilling conditions are dependent on requirements for tool life and surface finish. These conditions are further restricted by the rigidity of the tool and the workpiece, lubrication and machine power available. The harder the material, the lower the cutting speed.

Some materials of low hardness contain abrasive substances leading to rapid cutting edge wear at high speeds. Feed rates are governed by rigidity of set-up, volume of material to be removed, surface finish and available machine power.

Drilling a hole

Now that you have read the information and safety recommendations above, you are ready to actually start drilling. Follow these 12 steps for best drilling result :

1. Install the annular cutter.
 - Place the pilot pin into the cutter;
 - Align the flat faces on the cutter shank with the screws in the tool holder;
 - Make sure the cutter shank is entered fully and correctly;
 - Tighten the screws;

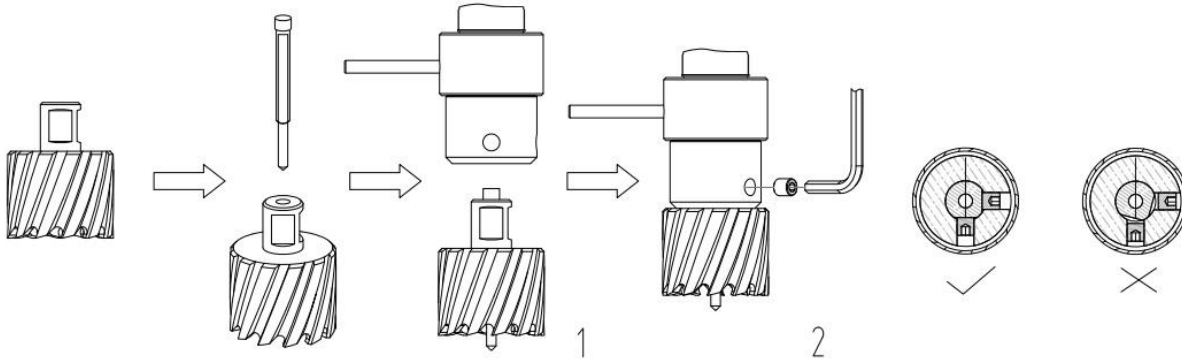

[image 3-1]

2. Precisely mark the centre of the hole.
3. Use the pilot pin to position the machine in the correct position, with the tip of the pilot pin to meet the marked center of the hole.
4. Switch on the machine and verify that the drill is in the right position and that the machine is pushed tight against the work piece.
5. Switch the motor on and allow it to run at the required speed.
6. Turn the feed handles to start drilling. Apply only a slight pressure when the annular cutter touches the metal. Do not push the annular cutter with force into the metal.
7. Apply a regular pressure while drilling. The drilling performance does not improve by putting more pressure on the machine. Too much pressure will overload the motor and your annular cutter will be worn sooner.
A continuous, non-discoloured iron swarf is a sign of correct drilling speed and a well-cooled, sharp cutter. Let the cutter do the job and give it time to cut the metal!
8. Apply less pressure when the drill cuts through the material. The slug will be pushed out of the cutter by the pilot pin.
9. Turn the feed handles to put the motor in highest position and switch off the motor unit.
10. Remove the burrs, metal chips and clean the cutter and surface without getting injuries.

Caution: The metal slug can be sharp and very hot!

6. Maintenance

Your Euroboor raildrilling machine has been designed to operate over a long period of time. Continuous satisfactory operation depends upon proper tool care and regular cleaning.



CAUTION: To reduce the risk of injury, turn the machine off before installing and removing accessories, before adjusting or changing set-ups or when making repairs. Be sure the switch is in the OFF position. An accidental start-up can cause injury.

Just as every rail drilling machine with moving parts, your Euroboor rail drilling machine also needs regular maintenance service. A few recommendations follow :

Visually check the machine for damage

The machine must be checked before operating for any signs of damage that will affect the operation of the machine. If the machine appears to be damaged it should not be used. Failure to do so may cause injury or death.

Cleaning

- Clean all dirt, dust, metal chips and burrs of your rail drilling machine;
- Blow dirt and dust out of the main housing with dry air as often as dirt is seen collecting in and around the air vents. Wear approved eye protection and an approved dust mask;
- Never use solvents or other harsh chemicals for cleaning the non-metallic parts of the tool. These chemicals may weaken the materials used in these parts. Use a cloth dampened only with water and mild soap. Never let any liquid get inside the tool; never immerse any part of the tool into a liquid.

Operation of the machine

The machines operation must be checked to ensure that all components are working correctly. Replace any defective parts immediately. This prevents properly functioning parts from being damaged.

Carbon brushes

Brushes should be checked to make sure there is no abnormal wear present. This should be checked at least once a week if used frequently. If the carbon brush has worn more than 2/3 the original length the brushes should be changed. Failure to do so may cause damage to the machine.

Check machines grease

The gearbox grease should be checked once a month to ensure all moving components are covered to prevent wear. The grease should be changed at least once a year to ensure you gain the best from the machine.

Check armature

This should be checked at least once a month to check if there are visual signs of damage to the body or to the commutator. Some signs of wear will be seen on the commutator over a period of time this is normal as this is the part that comes in contact with the brushes but any signs of abnormal damage means the part should be replaced.

Adjustment of slide

An essential requirement of the machine is that the slide can move in a smooth and controlled manner, free of lateral movement and vibration.

This situation can be maintained by periodic adjustment of the slide and can be accomplished in the following manner:

1. Place the machine in an upright position and, by means of the capstan, raise the slide to its highest position. Clean the aluminum rails;
2. Gently feed in setting screw with supplied Allen key 2.5 until slight resistance is encountered. Follow your way down adjusting all setting nuts and screws;
3. Operate the slide up and down a few times to test the movement and make any further necessary adjustments. Try to ensure that all the screws are exerting a uniform pressure on the slide from top to bottom. A perfectly adjusted slide will operate freely up and down without any sideways movement.

Lubricating the feed travel

The feed travel should be lubricated periodically with grease to ensure smooth operation.

- Raise the motor unit to the highest position possible;
- Lubricate the dove-tail guideway at both sides;
- Lubricate the gear rack.

After repeated use, the gear rack may become loose. If necessary, adjust the five self-locking set screws at the left side. Tighten screws in series until the gear rack moves freely in the dove-tail guideway but does not allow the motor to wobble.

Repair, modification and inspection

Repair, modification and inspection of Euroboor rail drilling machines must be done by Euroboor or an Euroboor authorized dealer. The spare parts list will be helpful if presented with the machine to the Euroboor dealer for service when requesting repair or other maintenance.

Euroboor machines are constantly being improved and modified to incorporate the latest technological advancements. Accordingly, some parts (i.e. part numbers and/or design) may be changed without prior notice. Also, due to Euroboor's continuing program of research and development, the specifications of machines are subject to change without prior notice.



WARNING: *Since accessories, other than those offered by Euroboor, have not been tested with this machine, use of such accessories with this tool could be hazardous. To reduce the risk of injury, only Euroboor recommended accessories should be used with this machine.*

Consult your dealer for further information on the appropriate accessories.

7. Trouble shooting

The motor does not work	<ul style="list-style-type: none"> - Damaged or defective wiring - Carbon brushes are stuck or worn out - Defective magnet switch - Defective On / Off switch - Defective control unit - Defective armature and/or field
Annular cutters break quickly, holes are bigger than the annular cutter	<ul style="list-style-type: none"> - Clearance in the guide - Bent spindle - Shaft extending from the motor is bent - Bent pilot pin
Motor running roughly and/or seizing up	<ul style="list-style-type: none"> - Bent spindle - Shaft extending from the motor is bent - Triangular guide not mounted straight - Dirt between spindle and triangular guide
Motor starts running when magnet switch is turned on	<ul style="list-style-type: none"> - Damage or defective relais in control unit
Motor making a rattling sound	<ul style="list-style-type: none"> - Gear ring (bottom of the armature) worn out - Gear(s) worn out - No grease in gearbox
Motor humming, big sparks and motor has no force	<ul style="list-style-type: none"> - Armature damaged (burned) - Field burned - Carbon brushes worn out
Motor does not start or fails	<ul style="list-style-type: none"> - Damaged or defective wiring - Dirt in sensor control unit - Damaged or defective (sensor) control unit - Damage to armature or field coil - Damaged or defective carbon brushes
Guiding takes a great deal of effort	<ul style="list-style-type: none"> - Guide is set too tight - Guide is dry, needs to be greased - Guide/gear- rack/rotation system dirty or damaged
Frame under voltage	<ul style="list-style-type: none"> - Damaged / defective wiring - Motor seriously dirty
Fuse blows when magnet switch is turned on	<ul style="list-style-type: none"> - Damaged or defective wiring - Wrong value fuse - Defective control unit
Fuse blows when motor is started	<ul style="list-style-type: none"> - Damaged or defective wiring - Wrong value fuse - Motor running roughly - Defective armature and / or field - Carbon brushes worn out - Defective control unit
Rotation system free stroke too long	<ul style="list-style-type: none"> - Loose or defective gear rack - Defective rotation system

8. Exploded view & spare part list

8.1 Exploded view

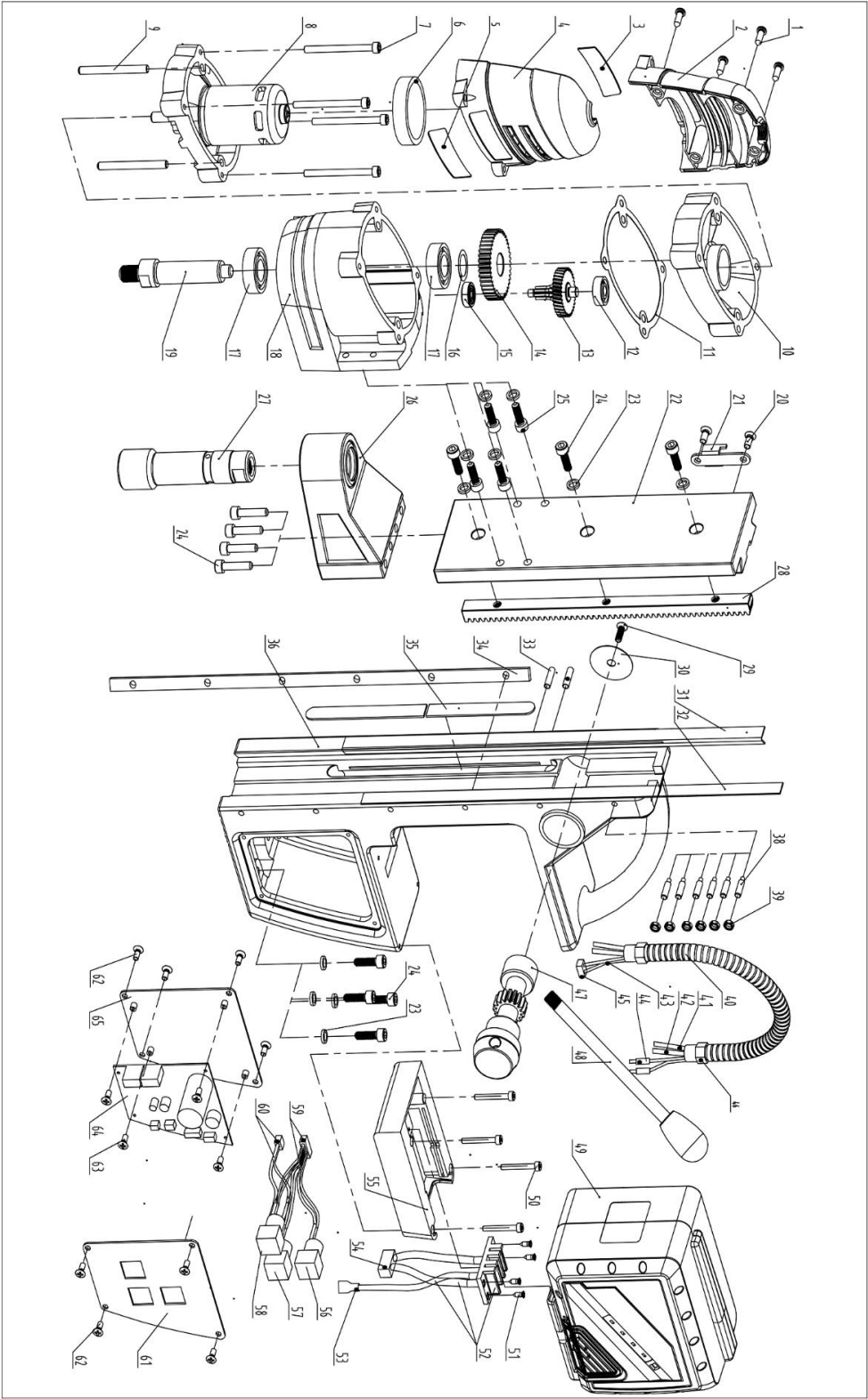

8.2 Spare part list

No	Part number	Description	Qty
1	032.0116	Screw M4 x 16	4
2	360.1002	Motorhousing left	1
3	360.1003	Label left	1
4	360.1004	Motorhousing right	1
5	360.1005	label right	1
6	360.1007	Bolt M5 x 60	4
7	360.1008	Motor unit assembly	1
8	360.1009	Pin 6 x 60	2
9	360.1010	Lower Inner gear plate	1
10	360.1011	Gasket	1
11	032.0221	Bearing 608 8 x 22 x 7	1
12	360.1013	Bevel gear assembly	1
13	360.1014	Spindle gear	1
14	360.1015	Bearing 626 ZZ	1
15	032.0191	Adapter ring 17 x 24 x 0.2	1
16	032.0196	Bearing 6003 DDU	2
17	360.1018	Gear casing	1
18	032.0201	Spindle drive shaft	1
19	KSP.MS	Screw M5 x 10	2
20	KSP.M/3	Tank holder	1
21	360.1027	Slide	1
22	020.0111	Washer M6 DIN7980	11
23	020.0156	Bolt M6 x 20	11
24	020.0106	Screw M6 x 14	4
25	360.1026	Steady	1
26	020.0116	Spindle complete 112 mm	1
27	360.1028	Rack	1
28	020.0081	End screw BKVZ M6 x 16	1
29	020.0077	End plate	1
30	360.1030	Rail set Aluminium (L/R) L-profile	1
31			
32	360.1050	Screw M5 x 25	1

No	Part number	Description	Qty
33	020.0229	Screw M4 x 20	6
33A	020.0229A	Screw M4 x 18	4
34	360.1035	Wires-Cover	2
35	360.1038	Frame 2019-05	1
39	360.1040	Motor cable cover	1
40	360.1041	Wire connector #1 +	1
41	360.1042	Wire #2	1
42+44	360.1043	Wire connector #3 +	1
43	360.1044	Wire #4	1
45	020.0041	Coupling nut PG9 (motor cable)	2
46	020.0061/XB	Capstan hub assembly black	1
47	020.0315	Arm for capstan	3
48	360.0004	Battery pack 2.6 Ah	1
48	360.0004	Battery pack 2.6 Ah	1
49	020.0059	Screw M4 x 25	2
48	360.0004	Battery pack 2.6 Ah	1
49	020.0059	Screw M4 x 25	2
50	360.1050	Bolt M4 x 30	2
51	360.1051	Screw ST2.9 x 8	4
52	360.1052	Battery contact board	1
53	360.1053	Connector	1
54	360.1054	Connector	2
55	360.1055	Battery slide base	1
56	360.1056	On switch	1
57	360.1057	Off switch	1
58	360.1058	Magnet switch	1
59	360.1059	Wire connector +	1
61	PP.F-EBM.360/2019	Front panel EBM.360/2019	1
62	020.0101	Panel screw BKVZ M4 x 8	8
63	360.1063	Screw M3 x 8	4
64	360.1064	Control-unit	1
65	PP.R-EBM.360/2019	Rear panel EBM.360/2019	1

8.3 Exploded view & spare parts Rail adapter

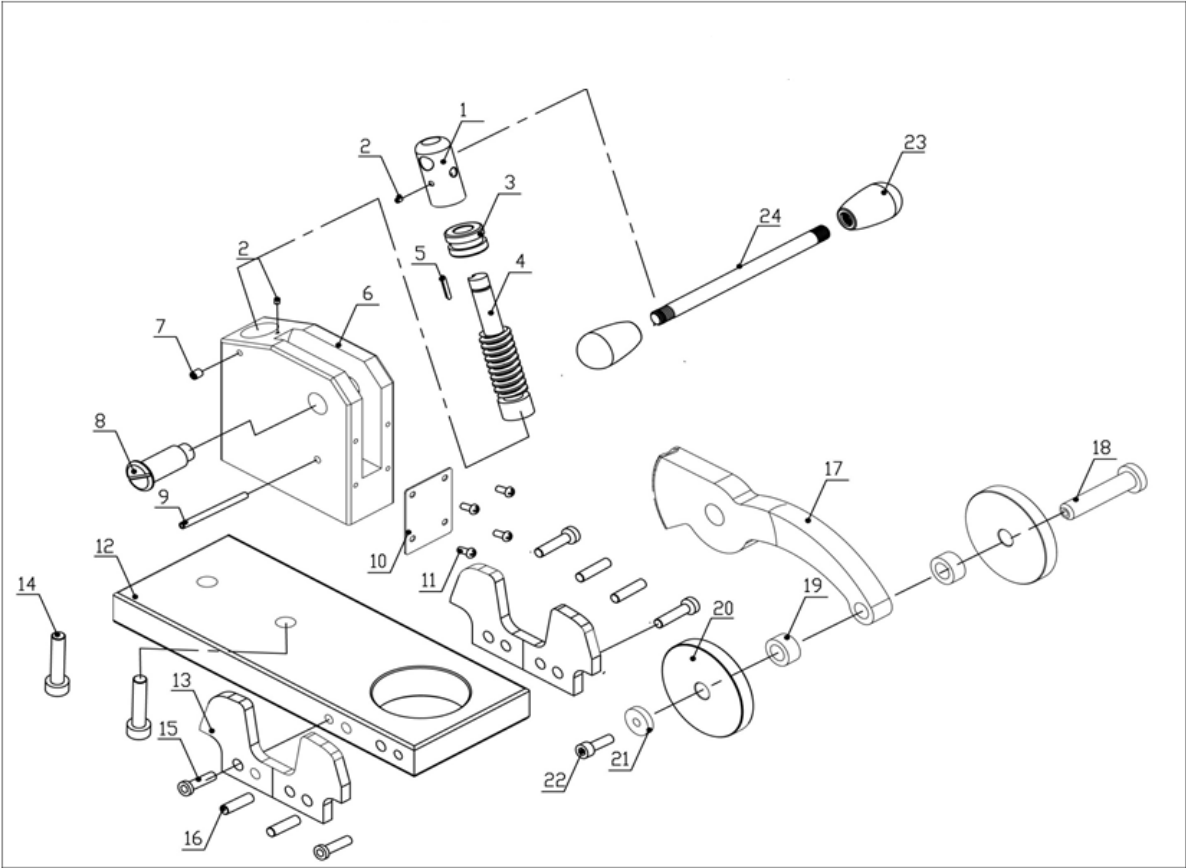

No.	Art.no	Description	Qty
1	020.0508	Worm set	1
2	020.0524	set	2
3	020.0514	Worm bushing	1
4	020.0500	worm	1
5	020.0523	Key	1
6	020.0502	The fixed frame	1
7	020.0525	Set	1
8	020.0513	Connecting bolts	1
9	020.0522	Flexible split pin	1
10	020.0511	Limit piece	1
11	020.0526	Screw	4
12	RAK.002/3	The base	1
13	RAK.002/3	clamp	2
14	020.0520	Inner hexagon bolt	2
15	020.0527	Inner hexagon bolt	4
16	020.0521	The positioning pin	4
17	020.0501	Worm gear radial	1
18	020.0506	Fixed pin	1
19	020.0505	Rocker arm bushing	2
20	020.0504	Rocker arm side panel	2
21	020.0507	The rocker gasket	1
22	020.0074	Screw	1
23	020.0066A	Arm-ball-for-capstan	2
24	020.0066H	Arm-stick-for-capstan	1

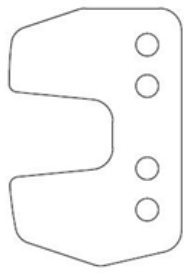

S49

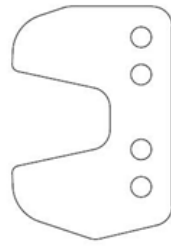

S54

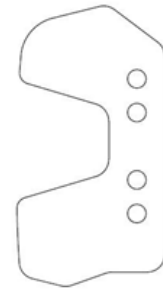

TR68

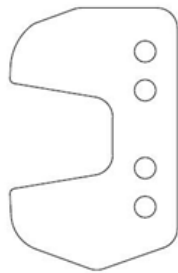

UIC50

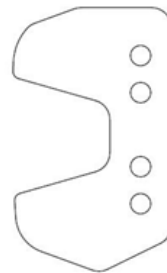

UIC54

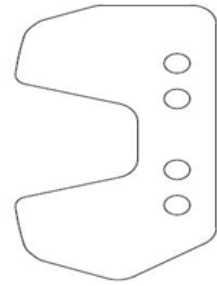

UIC60

Item	Spec.	Art.no
Adapter shape	S49	020.0532
	S54	020.0533
	TR68	020.0534
	UIC50	020.0535
	UIC54	020.0536
	UIC60	020.0537

8.4 Wiring diagram

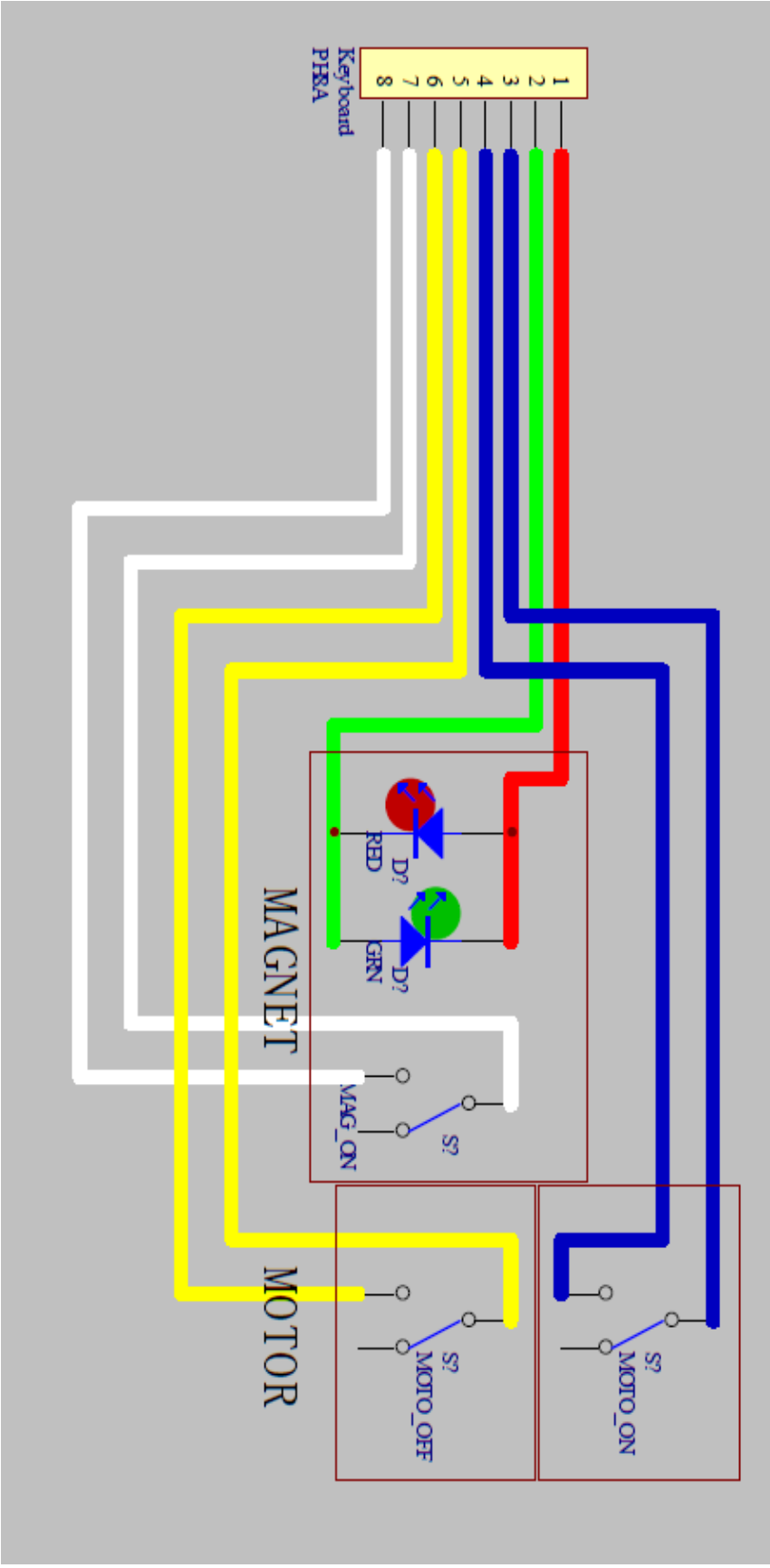

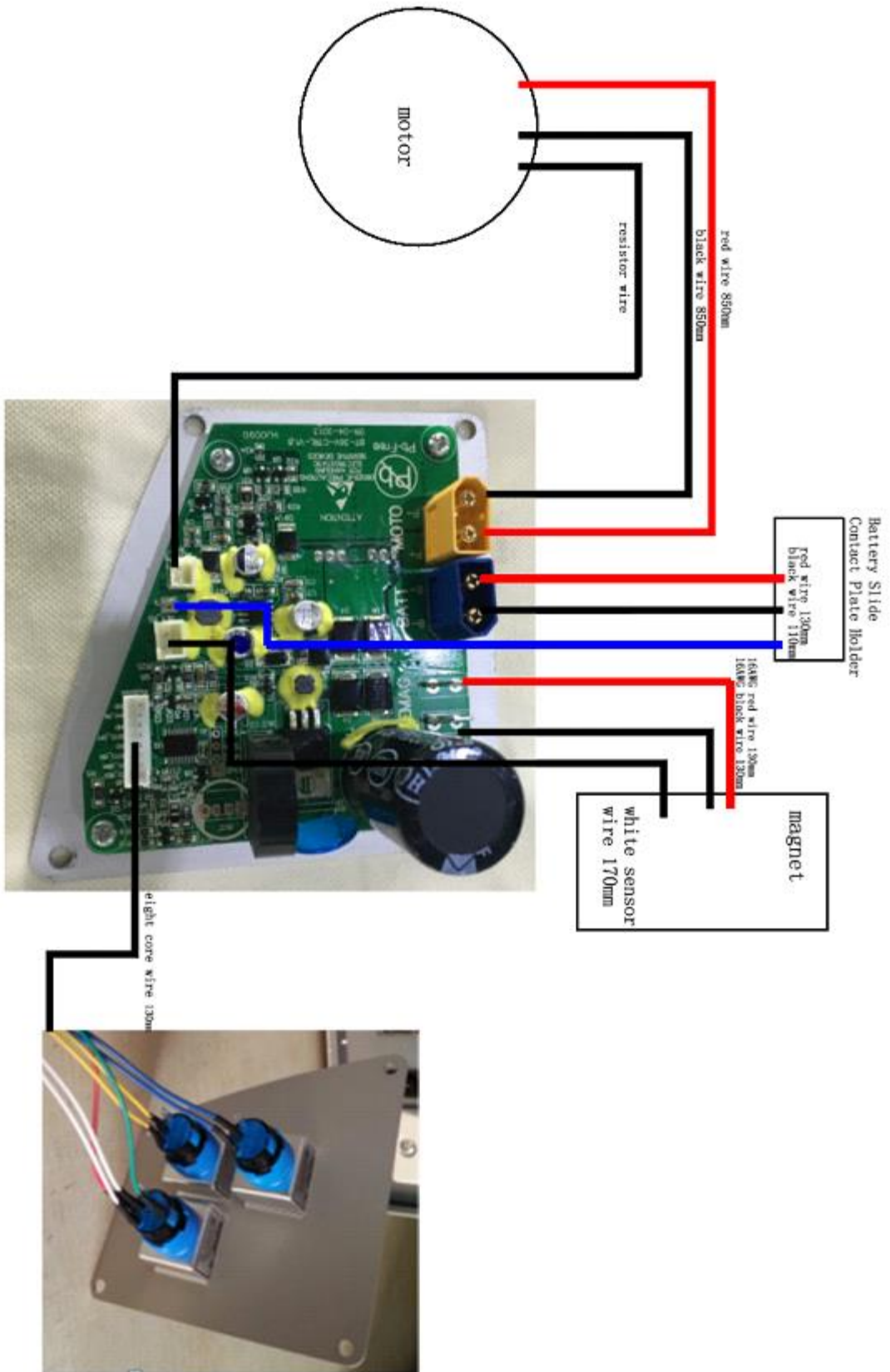

User manual
10-2019
For framenumbers:
60S1901xxx

 **EUROBOOR**
FOR PROFESSIONALS BY PROFESSIONALS

Rail drilling machine

RAIL.60S

Serial number:

Date of purchase:

Don't forget to register your machine at:

www.euroboor.com/register

[only when registered you benefit from extended warranty]

Congratulations on purchasing this premium rail drilling machine. At Euroboor we strive to exceed our customers' expectations by developing and providing premium and innovative portable drilling and cutting solutions. We believe that a professional like you must be able to rely on a professional supplier. Which has led us to become a major player in the industrial world, with our own factory and several offices worldwide. All because we have always listened to our customers and to the demands from the market.

Our vision is focused on developing innovative portable tools that add value for our customers and facilitate them in their daily work. We never lose sight of sustainability, time savings and cost savings.

Enjoy your new machine!

Before operating your new rail drilling machine, please first read all instructions. You find the instructions in this manual and on the warning label on your machine. With proper use, care and maintenance your machine will provide you with years of premium drilling performance.

TO REDUCE THE RISK OF INJURY USER MUST READ AND UNDERSTAND ALL INSTRUCTIONS

To view all our offices and their contact information please visit:

www.euroboor.com

Table of contents

Inhoudsopgave

1. Safety	4
1.1 General safety instructions.....	4
1.2 Specific safety information.....	6
2. Description	7
2.1 Intended use.....	7
2.2 Description and features.....	7
2.3 Box contents.....	8
2.4 Serial number.....	8
2.5 Technical data.....	9
2.6 Rail adapter.....	9
2.7 Symbols.....	10
2.8 Environmental.....	11
3. Preparation & adjustment	12
3.1 Assembly.....	12
3.2 Prior to use.....	12
4. Using the machine	14
4.1 Control panel.....	14
4.2 Morse Taper spindle.....	15
4.3 Gearbox.....	16
4.4 Switching motor on and off.....	17
4.5 Motor speed control.....	17
4.6 Temperature control.....	17
5. Working with operation tools	18
5.1 Annular cutters.....	18
6. Maintenance	20
7. Trouble shooting	22
8. Exploded view & spare parts list	23
8.1 Exploded view.....	23
8.2 Spare part list.....	26
8.3 Exploded view & spare parts rail adapter.....	28
8.4 Wiring diagram.....	31

1. Safety

1.1 General safety instructions

Do not use this rail drilling machine before you have thoroughly read and completely understood this manual, specifically the “General safety instructions” and “Specific safety information”, including the figures, specifications, safety regulations and the signs indicating DANGER, WARNING and CAUTION.



WARNING: When using electrical tools basic safety precautions should always be followed to reduce the risk of fire, electrical shock and personal injury.

Please also observe the relevant national industrial safety regulations. Non-observance of the safety instructions can lead to an electric shock, burns and/or severe injuries.

This manual should be kept for later use and enclosed with the rail drilling machine, should it be passed on or sold.

Work area

1. Keep your work area clean and well lit. Cluttered and dark work areas increase the chance of accidents.
2. Do not operate a rail drilling machine in explosive atmospheres, such as in the presence of flammable liquids, gases or dust. A rail drilling machine may create sparks which could ignite the dust or fumes.
3. Keep bystanders, children and visitors away while operating a rail drilling machine. Distractions can cause you to lose control.

Electrical safety

1. A rail drilling machine plug must match the outlet. Never modify the plug in any way. Do not use any adapter plugs.
2. Avoid body contact with grounded surfaces such as pipes, radiators, ranges and refrigerators. There is an increased risk of electric shock if your body is grounded.
3. Do not expose the rail drilling machine to rain or wet conditions. Water entering a machine will increase the risk of electric shock.
4. Do not abuse the cord. Never use the cord to carry the rail drilling machine or pull the plug from an outlet. Keep the cord away from heat, oil, sharp edges or moving parts. Replace damaged cords immediately. Damaged cords increase the risk of electric shock.
5. When operating a rail drilling machine, use an extension cord suitable for outdoor use, this reduces the risk of electric shock.
6. If operating a rail drilling machine in a damp location is unavoidable, use a residual current device (RCD), this reduces the risk of electric shock.

Personal safety

1. Stay alert, watch what you are doing and use common sense when using a rail drilling machine. Do not use the machine while tired or under the influence of drugs, alcohol, or medication. A moment of inattention while operating a rail drilling machine may result in serious personal injury.
2. Dress properly. Do not wear loose clothing or jewelry. Keep your hair, clothing and gloves away from moving parts. Loose clothes, jewelry, or long hair can be caught in moving parts.
3. Avoid accidental starting. Be sure the switch is off before plugging the machine in. Carrying a rail drilling machine with your finger on the switch or plugging in a rail drilling machine that has the switch on increases the change of accidents.
4. Never place hands, fingers, gloves or clothing near drilling area or rotating machine parts.
5. Remove adjusting keys or switches before turning the machine on. A wrench or a key that is left attached to a rotating part of the machine may result in personal injury.
6. Do not overreach. Keep proper footing and balance at all times. Proper footing and balance enables better control of the rail drilling machine in unexpected situations.
7. Use safety equipment. Always wear eye protection. Dust mask, non-skid safety shoes, hard hat and hearing protection must be used for optimal safety.

When using this machine, you MUST wear ear and eye protection.

Machine use and care

1. While operating the machine, the annular cutter must be cooled and lubricated
2. Always remove the slug from the annular cutter after each hole. **Caution;** the slug may be hot!
3. Do not use the machine when the switch does not turn it on or off. Any machine that cannot be controlled with the switch is dangerous and must be repaired.
4. Disconnect the plug from the power source before making any adjustments, changing accessories or storing the tool. Such preventive safety measures reduce the risk of starting the tool accidentally.
5. Store your rail drilling machine out of reach for children and other untrained persons. Tools are dangerous in the hands of untrained users.
6. Maintain your machine with care. Keep cutting tools sharp and clean. Properly maintained tools, with sharp cutting edges are less likely to break and are easier to control.
7. Check for misalignment of moving parts, breakage of parts and any other condition that may affect the machine's operation. If you detect damage have the machine serviced before use. Many accidents are caused by poorly maintained tools.
8. Only use accessories that are recommended by Euroboor for your machine model. Accessories that are suitable for one machine may become hazardous when used on another machine.

Service

1. Tool service must be performed only by qualified repair personnel. Service or maintenance performed by unqualified personnel could result in risk of injury.
2. When servicing a tool, use only identical replacement parts. Follow instructions in the maintenance section of this manual. Use of unauthorized parts or failure to follow maintenance instructions may create a risk of electric shock or injury.
3. Euroboor offers Armature kits containing official Euroboor spare parts suitable for your rail drilling machine.

1.2 Specific safety information

- Keep your fingers away from the drilling area;
- Avoid touching the slug that is automatically ejected by the pilot pin when the working procedure is finished. Contact with the slug when it is hot, or if it falls, can cause personal injuries;
- Do not switch on the machine before checking whether the stand has been tightened firmly to the mounting surface;
- Adjust the machine so cutter does not extend into the workpiece before drilling. Do not perform any design, assembly or construction activities on the workpiece while the machine is switched on;
- Before switching on the machine, make sure all accessories have been mounted correctly;
- Do not switch on the machine until it has been mounted and installed according to all above mentioned instructions;
- Always use the recommended speed for the accessories and material you are working with;
- Do not use the machine on the same workpiece on which electric welders are working;
- In case of a jammed cutter, turn off the machine, disconnect the machine from the power supply and then remove the reason for the jam before turning on the machine again.

Residual risk

In spite of following the relevant safety regulations and their implementation, certain residual risks cannot be avoided.

These are:

- Impairment of hearing
- Risk of personal injury from flying particles
- Risk of burns due to accessories becoming hot during operation
- Risk of personal injury due to prolonged use.

Always try to reduce these risks as much as possible.

2. Description

2.1 Intended use

This rail drilling machine is intended for commercial use as a drilling machine for drilling. Use always tools and accessories recommended by Euroboor.

2.2 Description and features

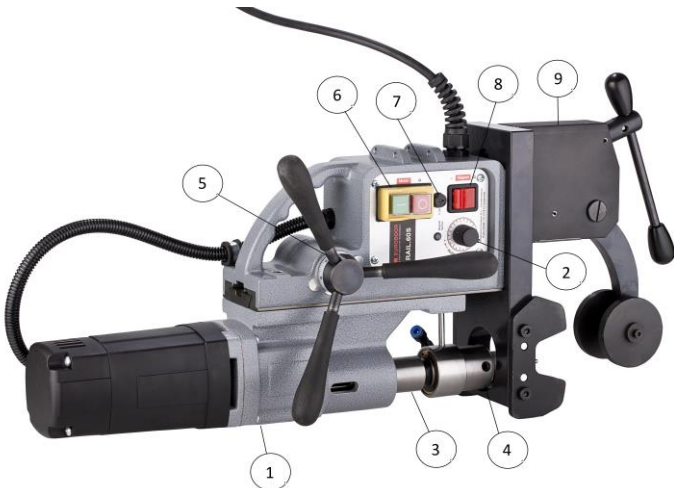

- 1 Gearbox guide
- 2 RPM dial
- 3 Output shaft
- 4 Morse Taper spindle
- 5 Feed Handle
- 6 Motor Switch
- 7 Fuse holder
- 8 Magnet switch
- 9 Rail adapter

[image 1-1]

2.3 Case content

- 1 x RAIL.60S+ rail drilling machine
- 3 x handles
- 1 x hex key 2.5 mm
- 1 x hex key 4 mm
- 1 x hex key 5 mm
- 1 x arbor MT 3 – 19,05 (3/4")
- 1 x morse taper ejector drift key
- 1 x user manual
- 1 x safety ear protection
- 1 x safety goggles
- 1 x safety gloves

2.4 Serial number

The serial number is mentioned on the machine two times: engraved on the frame and on the serial no. sticker on the motor housing. Additional serial no. stickers are provided with the machine for your administration.

The serial number will help you, your dealer and Euroboor to validate and identify the machine.

For example:

060S1909001

breaks down to:

<i>060S</i>	<i>19</i>	<i>09</i>	<i>001</i>
Machine series			
	Year of manufacture		
		Month of manufacture	
			Identification number







2.5 Technical data

	Metric	Imperial
Annular cutting	Ø 12 – 36 mm	Ø 7/16" – 1 7/16"
Length	262 mm	10 5/16"
Width	130mm	5 1/8"
Height	597 – 747 mm	23 1/2" – 29 7/16"
Stroke	170 mm	6 11/16"
Weight	14,5 kg	32 lbs
Motor power	1600 W	14.5 A
Total power	1700 W	15.5 A
Speed (no load)	[I] 60 – 275 rpm	[I] 60 – 275 rpm
Speed (load 1600 W)	[II] 100 – 500 rpm	[II] 100 – 500 rpm
Spindle (Weldon)	MT3 19,05 mm	MT3 3/4"
Voltage	110 – 120 V / 60 Hz 220 – 240 V / 50 – 60 Hz	

2.6 Rail Adapter

The rail drilling machine is specifically designed for drilling in rails. The rail drilling machine is available in various versions, ensuring there is always the right rail adapter for the job. The rail adapter versions that we offer are: S49, S54, TR68, UIC50, UIC54 and UIC60.

2.7 Symbols

Symbol	Term, meaning	Explanation
	Read documentation	Be absolutely sure to read the documentation in this user manual and specifically the “General safety instructions” and “Specific safety information”.
	Wear ear protection	Use ear protection during operation.
	Wear eye protection	Use eye protection during operation.
	Danger/warning/caution	Read and apply the information in the adjacent text!
	European conformity symbol	Confirms the conformity of the rail drilling machine with the directives of the European Community.
	Class of protection I	Product with basic insulation and exposed (touchable) conductive parts additionally connected to the protective earth conductor.
mm	Millimeter	Unit of measurement for length, width, height or depth.
kg	Kilogram	Unit of measurement for the mass.
V	Volt	Unit of measurement for the electric voltage.
A	Ampere	Unit of measurement for the electric current intensity
W	Watt	Unit of measurement for the output.
rpm	Revolutions per minute	Unit of measurement for the revolutions.
no	No load speed	Revolution speed at no load.

2.8 Environmental



Separate collection. This product must not be disposed of with normal household waste.



Separate collection of used products and packaging allows materials to be recycled and used again. Re-use of recycled materials helps prevent environmental pollution and reduces the demand for raw materials.

Local regulations may provide for separate collection of electrical products from the household, at municipal waste sites or at the retailer when you purchase a new product.

3. Preparation & adjustment

3.1 Assembly



WARNING: To reduce the risk of injury, turn machine off and disconnect from power source before installing and removing accessories, before adjusting or changing set-ups or when making repairs. Be sure all switches are in the OFF position. An accidental start-up can cause injury.

Fitting the feed handles

1. Fit each of the three feed handles by screwing them into the hub in clockwise direction.
2. Tighten firmly by hand.

The handles are supposed to face slightly outward. Be careful not to cross-thread any of the components.

3.2 Prior to use

Check the machine for possible damage; Before using the machine, you must carefully check the protective components or slightly damaged components to ensure they are operating perfectly and as intended.

Check that moving parts are in perfect working order, do not jam and check whether the parts are damaged. All parts must be correctly installed and fulfill all conditions necessary to ensure perfect operation of the machine.

Damaged protective components must be repaired or replaced according to specifications by Euroboor or any authorized Euroboor dealer.

DO NOT use under wet conditions or in presence of flammable liquids or gases.

DO NOT let children come into contact with the machine. Supervision is required when inexperienced operators use this machine.

Electrical safety

The electric motor has been designed for one voltage only. Always check that the power supply corresponds to the voltage on the rating plate.

Your Euroboor rail drilling machine is designed in class I (grounded) according to EN 61029-1. Earth wire is required.

If the supply cord is damaged, it must be replaced by a specially prepared cord available at Euroboor or your Euroboor dealer.

Extension cable

If an extension cable is required, use an approved 3-core extension cable suitable for the power input of this machine (see technical data). The minimum conductor size is 1.5 mm²; the maximum length is 30 meter. When using a cable reel, always unwind the cable completely.

Useful tips

- Try a few simple projects using old rails until you develop a ‘feel’ for the rail drilling machine
- Let the machine run in for a period of eight to ten hours before starting with big operations
Do not load the machine too much during this run-in period.
- Never use the machine with serious overload
- Keep the machine clear from moisture at all times to protect the machine, yourself and others

4. Using the machine

 **WARNING:** Always observe the safety instructions and applicable regulations.

 **WARNING:** To reduce the risk of serious personal injury, turn the machine off and disconnect the machine from power source before making any adjustments or removing/installing attachments or accessories.

4.1 Control panel

The control panel on your rail drilling machine is designed for maximum ease of use and safety.

- 1. Motot Switch.
- 2. Magnet LED Indicator
- 3. Fuse Holder
- 4. RPM Dial
- 5. Magnet Switch

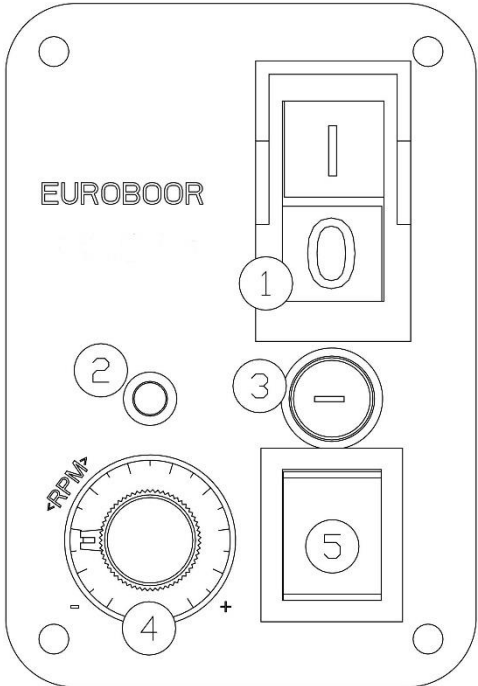

[image 2-2]

4.2 Morse taper spindle

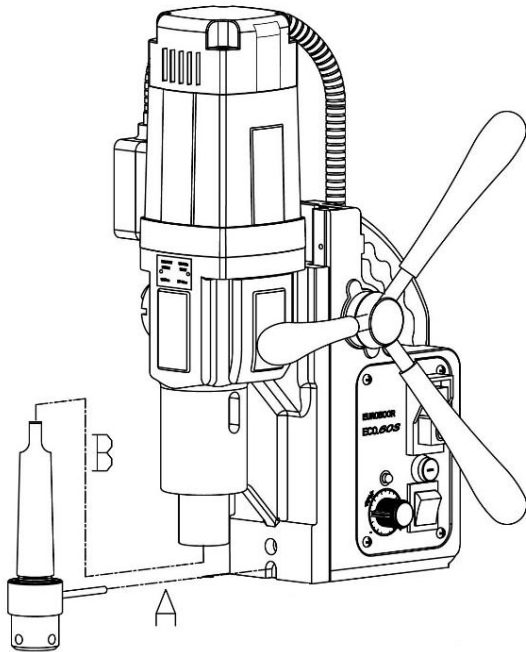

[image 2-3]

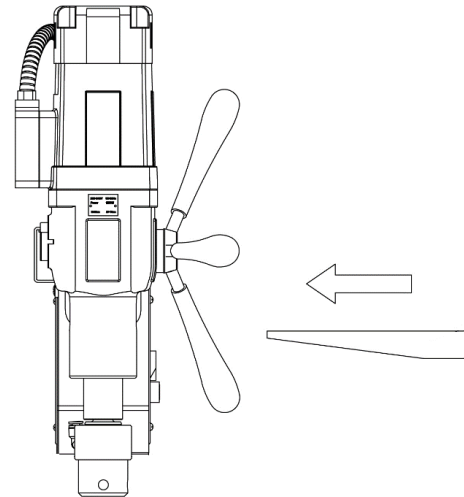

[image 2-4]

1. Make sure the inside of the output shaft and the Morse Taper spindle are clean and free of grease;
2. Align the coolant ring rotation limiter with the recess in the gearbox (A);
3. Firmly slide the Morse Taper spindle into the output shaft by hand (B). Make sure the spindle is properly positioned. You should not be able to pull it out by hand;
4. To remove the Morse Taper spindle:
 - Switch of the motor;
 - Rotate the mechanical gear switch to neutral (see chapter Gearbox 4.3);
 - Rotate the output shaft until the slots on the shaft align with the slots on the gearbox;
 - Gently tap the supplied drift into the slots to push the Morse Taper arbor out.

4.3 Gearbox

1. To select the correct gear from neutral (horizontal) position:
 - a. Rotate the switch counter clockwise to position **o**, this is gear 1.
 - b. Rotate the switch clockwise to position **oo**, this is gear 2.
2. A gear is only correctly selected when the gearbox switch is aligned with the indicators on the gearbox.

In case you have trouble fully and correctly selecting a gear, the gears in the gearbox might be misaligned. Slightly rotating the output shaft by hand will help you align the gears correctly and fully select the intended gear.

3. Speed selection for annular cutters (also see plate on gearbox):
 - o** \varnothing 27-60 mm Rotating speed 60-275 rpm
 - oo** \varnothing 12-26 mm Rotating speed 100-500 rpm

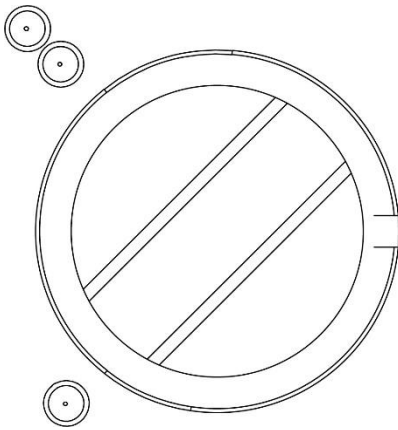

[image 2-5]



WARNING: *never touch moving machine parts!*

4.4 Switching motor on and off

The motor unit can only be switched ON when the magnet switch is activated. Although it is a rail drilling machine, there is a magnet switch. The machine is in fact a converted magnetic drilling machine. To switch the motor ON, press the green button with marking "I". To switch the motor OFF, press the red button with marking "O".

4.5 Motor speed control

The RPM dial allows you to electronically control the speed of the motor (in both clockwise and counter clockwise direction).

- The indicator of the RPM dial in bottom left corner is minimum speed.
- The indicator of the RPM dial in bottom right corner is maximum speed.

The electronic motor speed control works for both mechanical gears. Be careful not to overturn the dial.

4.6 Temperature control

This machine is equipped with an all-time electronic temperature protection. If the temperature of the motor unit runs up to 70 Degree Celsius the motor unit will stop. After a few minutes it can be started again. When it is possible to start the motor again, let the motor run idle at full speed for a couple of minutes to let the motor cool down more in an efficient way.

5. Working with drilling accessories

5.1 Annular cutters

Annular cutters only cut material at the periphery of the hole, rather than converting the entire hole to shavings. As a result, the energy required to make a hole is lower than for a twist drill. When drilling with an annular cutter, it is not necessary to drill a pilot hole.

 **WARNING:** Do not touch the cutter or the parts close to the cutter immediately after operation, as they may be extremely hot and cause burns to the skin. Ensure nobody is in the work area where the metal core (slug) is ejected.

Drilling conditions

The ease with which material can be drilled depends on several factors including tensile strength and abrasion resistance. Whilst hardness and/or strength is the usual criterion, wide variations in machinability can exist among material showing similar physical properties.

The drilling conditions are dependent on requirements for tool life and surface finish. These conditions are further restricted by the rigidity of the tool and the workpiece, lubrication and machine power available. The harder the material, the lower the cutting speed.

Some materials of low hardness contain abrasive substances leading to rapid cutting edge wear at high speeds. Feed rates are governed by rigidity of set-up, volume of material to be removed, surface finish and available machine power.

Drilling a hole

Now that you have read the information and safety recommendations above, you are ready to actually start drilling. Follow these 12 steps for best drilling result :

1. Install the annular cutter.
 - Place the pilot pin into the cutter;
 - Align the flat faces on the cutter shank with the screws in the tool holder;
 - Make sure the cutter shank is entered fully and correctly;
 - Tighten the screws;

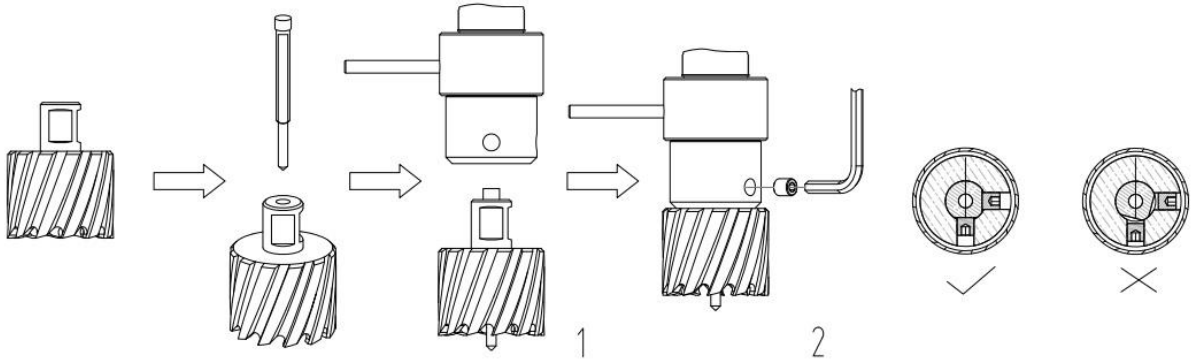

[image 3-1]

2. Precisely mark the center of the hole.
3. Use the pilot pin to position the machine in the correct position, with the tip of the pilot pin to meet the marked center of the hole.
4. Switch on the machine and verify that the drill is in the right position and that the machine is pushed tight against the work piece.
5. Switch the motor on and allow it to run at the required speed.
6. Turn the feed handles to start drilling. Apply only a slight pressure when the annular cutter touches the metal. Do not push the annular cutter with force into the metal.
7. Apply a regular pressure while drilling. The drilling performance does not improve by putting more pressure on the machine. Too much pressure will overload the motor and your annular cutter will be worn sooner.
A continuous, non-discoloured iron swarf is a sign of correct drilling speed and a well-cooled, sharp cutter. Let the cutter do the job and give it time to cut the metal!
8. Apply less pressure when the drill cuts through the material. The slug will be pushed out of the cutter by the pilot pin.
9. Turn the feed handles to put the motor in highest position and switch off the motor unit.
10. Remove the burrs, metal chips and clean the cutter and surface without getting injuries.

Caution: The slug can be sharp and very hot!

6. Maintenance

Your Euroboor rail drilling machine has been designed to operate over a long period of time. Continuous satisfactory operation depends upon proper tool care and regular cleaning.



CAUTION: To reduce the risk of injury, turn the machine off and disconnect machine from power source before installing and removing accessories, before adjusting or changing set-ups or when making repairs. Be sure the switch is in the OFF position. An accidental start-up can cause injury.

Just as every rail drilling machine with moving parts, your Euroboor rail drilling machine also needs regular maintenance service. A few recommendations follow :

Visually check the machine for damage

The machine must be checked before operating for any signs of damage that will affect the operation of the machine. Particular notice must be taken of the main cable, if the machine appears to be damaged it should not be used. Failure to do so may cause injury or death.

Cleaning

- Clean all dirt, dust, metal chips and burrs of your rail drilling machine;
- Blow dirt and dust out of the main housing with dry air as often as dirt is seen collecting in and around the air vents. Wear approved eye protection and an approved dust mask;
- Never use solvents or other harsh chemicals for cleaning the non-metallic parts of the tool. These chemicals may weaken the materials used in these parts. Use a cloth dampened only with water and mild soap. Never let any liquid get inside the tool; never immerse any part of the tool into a liquid.

Operation of the machine

The machines operation must be checked to ensure that all components are working correctly. Replace any defective parts immediately. This prevents properly functioning parts from being damaged.

Check machine oil

The gearbox oil should be checked and replaced at least once a year to ensure maximum lubrication and cooling, and thus the best performance of the machine.

Check armature

This should be checked at least once a month to check if there are visual signs of damage to the body or to the commutator. Some signs of wear will be seen on the commutator over a period of time this is normal as this is the part that comes in contact with the brushes but any signs of abnormal damage means the part should be replaced.

Adjustment of slide

An essential requirement of the machine is that the slide can move in a smooth and controlled manner, free of lateral movement and vibration.

This situation can be maintained by periodic adjustment of the slide and can be accomplished in the following manner:

1. Place the machine in an upright position and, by means of the capstan, raise the slide to its highest position. Clean the aluminum;
2. Gently feed in setting screw with supplied Allen key 2.5 until slight resistance is encountered. Follow your way down adjusting all setting nuts and screws;
3. Operate the slide up and down a few times to test the movement and make any further necessary adjustments. Try to ensure that all the screws are exerting a uniform pressure on the slide from top to bottom. A perfectly adjusted slide will operate freely up and down without any sideways movement.

Lubricating the feed travel

The feed travel should be lubricated periodically with grease to ensure smooth operation.

- Raise the motor unit to the highest position possible;
- Lubricate the dove-tail guideway at both sides;
- Lubricate the gear rack.

After repeated use, the gear rack may become loose. If necessary, adjust the five self-locking set screws at the left side. Tighten screws in series until the gear rack moves freely in the dove-tail guideway but does not allow the motor to wobble.

Repair, modification and inspection

Repair, modification and inspection of Euroboor rail drilling machines must be done by Euroboor or an Euroboor authorized dealer. The spare parts list will be helpful if presented with the machine to the Euroboor dealer for service when requesting repair or other maintenance.

Euroboor machines are constantly being improved and modified to incorporate the latest technological advancements. Accordingly, some parts (i.e. part numbers and/or design) may be changed without prior notice. Also, due to Euroboor's continuing program of research and development, the specifications of machines are subject to change without prior notice.



WARNING: *Since accessories, other than those offered by Euroboor, have not been tested with this machine, use of such accessories with this tool could be hazardous. To reduce the risk of injury, only Euroboor recommended accessories should be used with this machine.*

Consult your dealer for further information on the appropriate accessories.

7. Trouble shooting

The motor does not work	<ul style="list-style-type: none"> - Damaged or defective wiring - Carbon brushes are stuck or worn out - Defective magnet switch - Defective On / Off switch - Defective control unit - Defective armature and/or field
Annular cutters break quickly, holes are bigger than the annular cutter	<ul style="list-style-type: none"> - Clearance in the guide - Bent spindle - Shaft extending from the motor is bent - Bent pilot pin
Motor running roughly and/or seizing up	<ul style="list-style-type: none"> - Bent spindle - Shaft extending from the motor is bent - Triangular guide not mounted straight - Dirt between spindle and triangular guide
Motor starts running when magnet switch is turned on	<ul style="list-style-type: none"> - Damage or defective relays in control unit
Motor making a rattling sound	<ul style="list-style-type: none"> - Gear ring (bottom of the armature) worn out - Gear(s) worn out - No oil in gearbox
Motor humming, big sparks and motor has no force	<ul style="list-style-type: none"> - Armature damaged (burned) - Field burned - Carbon brushes worn out
Motor does not start or fails	<ul style="list-style-type: none"> - Damaged or defective wiring - Dirt in sensor control unit - Damaged or defective (sensor) control unit - Damage to armature or field coil - Damaged or defective carbon brushes
Guiding takes a great deal of effort	<ul style="list-style-type: none"> - Guide is set too tight - Guide is dry, needs to be greased - Guide/gear- rack/rotation system dirty or damaged
Frame under voltage	<ul style="list-style-type: none"> - Damaged / defective wiring - Motor seriously dirty
Fuse blows when magnet switch is	<ul style="list-style-type: none"> - Damaged or defective wiring
Turned on	<ul style="list-style-type: none"> - Wrong value fuse - Defective control unit
Fuse blows when motor is started	<ul style="list-style-type: none"> - Damaged or defective wiring - Wrong value fuse - Motor running roughly - Defective armature and / or field - Carbon brushes worn out - Defective control unit
Rotation system free stroke too long	<ul style="list-style-type: none"> - Loose or defective gear rack - Defective rotation system

8. Exploded view & spare part list

8.1 Exploded view

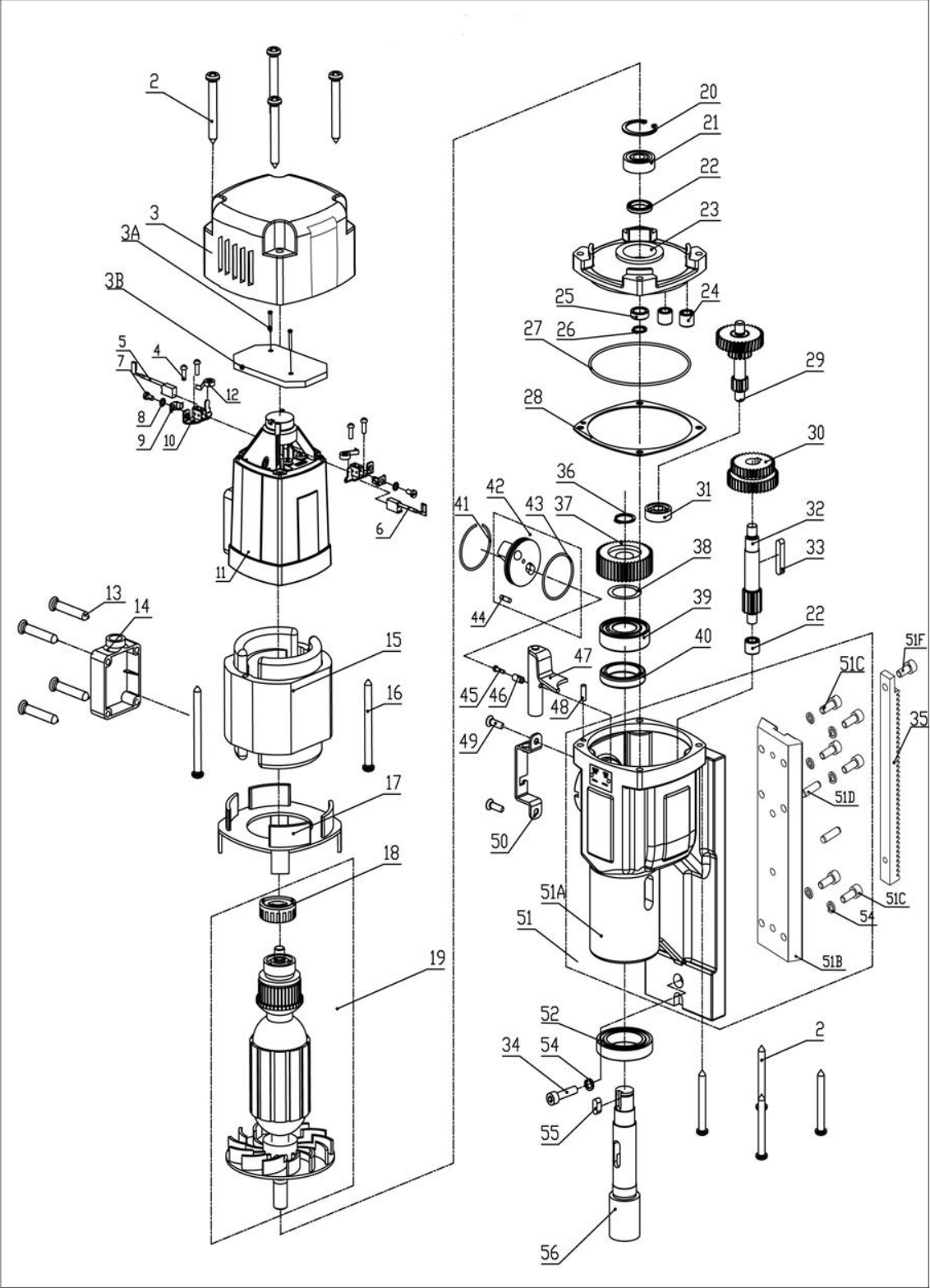

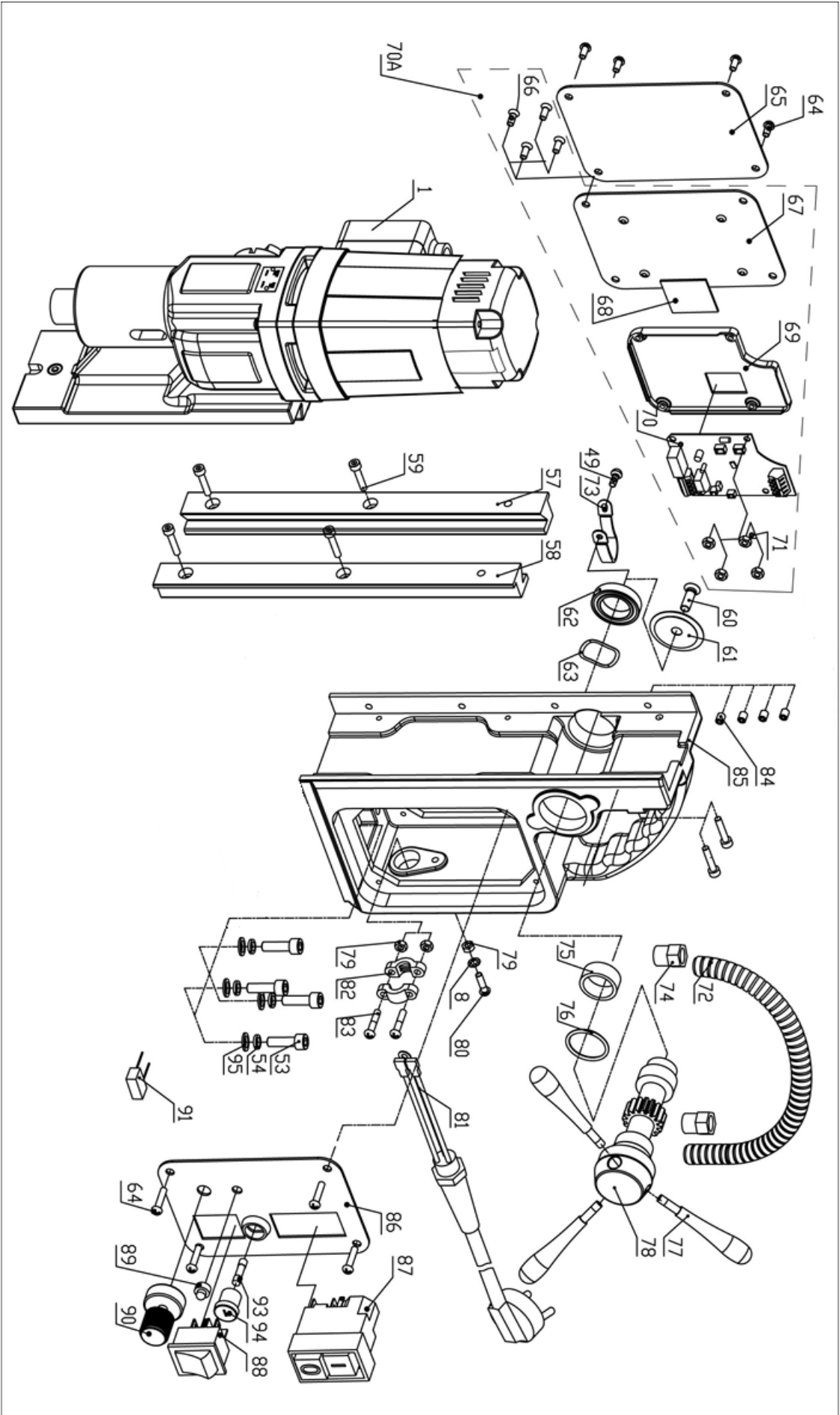

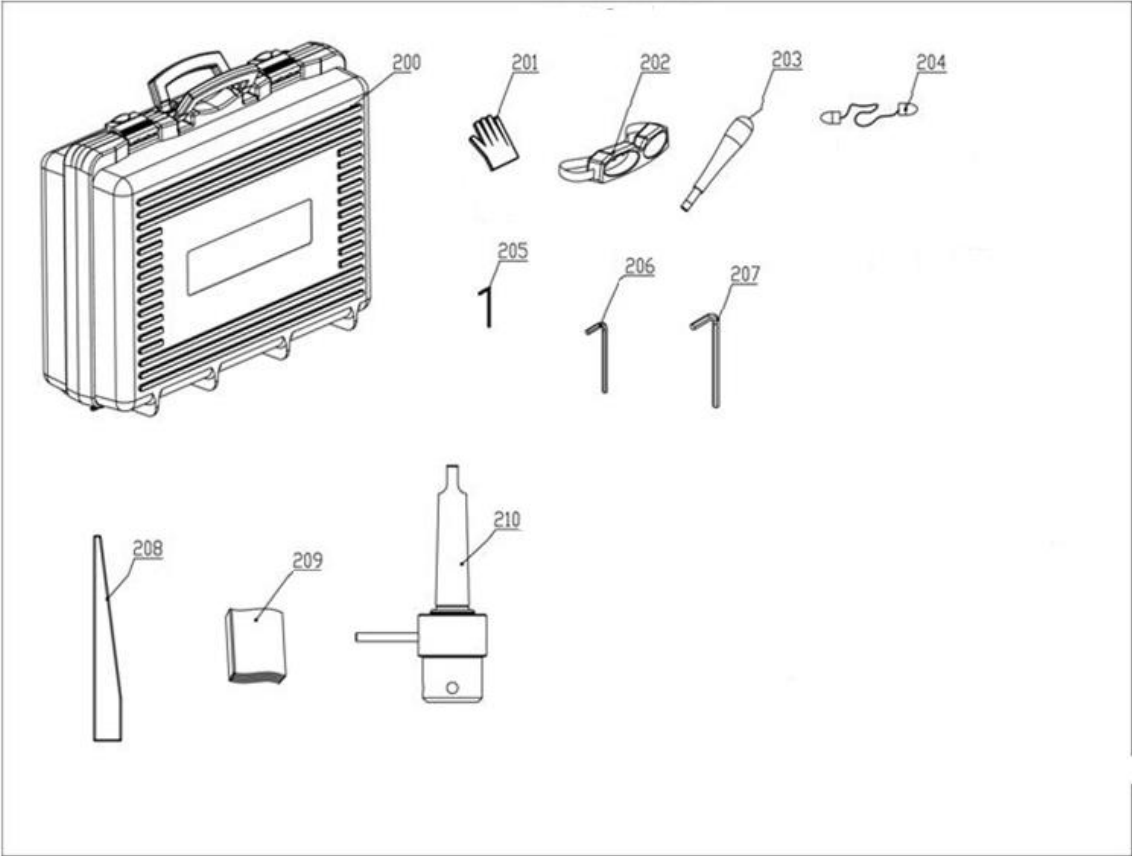

8.2 Spare part list

No	Part number	Description	Qty
1	060.1001	Motor unit 220V	1
	060.1001A	Motor unit 110V	
2	100.0306	Screw	8
3	050.0111	End cover	1
3A	050T.0332	Screw	2
3B	050T.0006	Test-circuit-board	1
5-6	050.0069	Carbon brush set 220V	1
	050.0070	Carbon brush set 110V	
4, 7-10, 12	050.0067	Carbon brush holder assembly	2
11	050.0131	Housing	1
13	050.0587	Screw	4
14	050.0586	Cable housing	1
15	050T.0278	Field 220V	1
	050T.0278A	Field 110V	
16	020.0328	Screw	2
17	050.0261	Baffle	1
18-19	050T.0183	Armature set 220V	1
	050T.0183A	Armature set 110V	
20	032.0166	Circlip	1
21	032.0171	Bearing	1
22	050.0064	Oil bearing	1
23	050.0236/Y	Inner gear plate	1
24	040.0161	Bearing	3
25	050.0065	Metal ring	1
26	050.0176	Circlip	1
27	050.0071	O-ring	1
28	050.0207	Gasket	1
29	050.0252	Gear set	1
30	050.0171	Gear	1
31	032.0126	Bearing	1
32	050.0231	Gear	1
33	100.4496	Key	1
34	020.0146	Screw	1
35	050.0074	Rack	1
36	050.0076	Circlip	1
37	050.0463	Gear	1
38	050.0462	Washer	1
39	030.0009	Bearing	1
40	050.0066	Oil bearing	1
41	050.0078	Ring	1
42	050.1014	Gear switch set	1
43	050.0081	O-ring	1
44	050.0025	PIN	1
45	020.0329	Screw	1
46	050.0082	Screw holder	1
47	050.1005A	Clutch shaft set	1
48	032.0211	Pin	1
49	KSP.MS	Screw	3
50	KSP.M/3	Coolant hanger	1
51	060.1019	Gear box set	1

No	Part number	Description	Qty
51A	055.0008G	Gear casing	1
51B	055.0028G	Slide	1
51C	020.0106	Screw	6
51D	020.0003	Pin	2
51F	030.0012	Screw	1
52	050.0068	Bearing	1
53	020.0156	Screw	4
54	020.0111	Washer	1
55	050.0077	Key	1
56	050.0461	Spindle drive shaft	1
57-58	020.0086/Z	Rail set Alu (L+R) Z-profile	1
59	020.0063	Screw	6
60	020.0081	Screw	1
61	050.0030	End cover	1
62	050.0063	Bearing	1
63	040.0023	Washer	1
64	020.0101	Screw	8
65	055.0002	Rear panel plate 220V	1
	055.0002A	Rear panel plate 110V	
66-71	050T.1018	Speed control unit 220V	1
	050T.1018A	Speed control unit 110V	
72	020.0046	Motor cable tube	1
73	020.0298	Motor cable clamp	1
74	020.0041/H	Coupling Nut for motor cable	2
75	032.0127	Powder metal bearing	1
76	030.0027	Washer	1
77	020.0315	Feed arm	3
78	020.0061/XB	Capstan hub	1
79-80, 82	020.0182	Grounding screw/washer/nut	3
81	020.0036	Main cable complete 220-240V	1
	020.0036/AU	Main cable Australia	
	020.0036/UK	Main cable UK 220V	
	020.0036/UK 110-16A	Main cable UK 110V 16A	
	020.0036/USA	Main Cable USA	
79, 82-83	020.0037	Cable clamp	1
84	020.0231	Screw	4
85	020.0056/Z	Frame	1
86	PP.F-ECO.60S	Front panel plate	1
87	030E.0091/Y	On/off switch 220V	1
	030E.0092/Y	On/off switch 110V	
88	020.0011	Magnet switch	1
89	020.0206	LED set	1
90	060.1009	Potentiometer set	1
91	060.1030	Capacitor set	1
93	020.0017	Fuse	1
94	020.0016	Fuse holder	1
95	020.0112	Washer	4

200	CAS.50s	Machine case	1
201	SAF.300	Protective gloves	1
202	SAF.100	Safety goggles	1
203	O20.0315	Arm for capstan	1
204	SAF.200	Ear plugs	1
205	IMB.US2.5	Allen key 2.5 mm	3
206	IMB.US4	Allen key 4 mm	1
207	IMB.US5	Allen key 5 mm	1
208	drift3	Drift MT3	1
209	Website download	Manual	1
210	IMC.30/19-N	Arbor MT3 - 19.05 (3/4") Weldon	1

8.3 Exploded view & spare parts Rail adapter

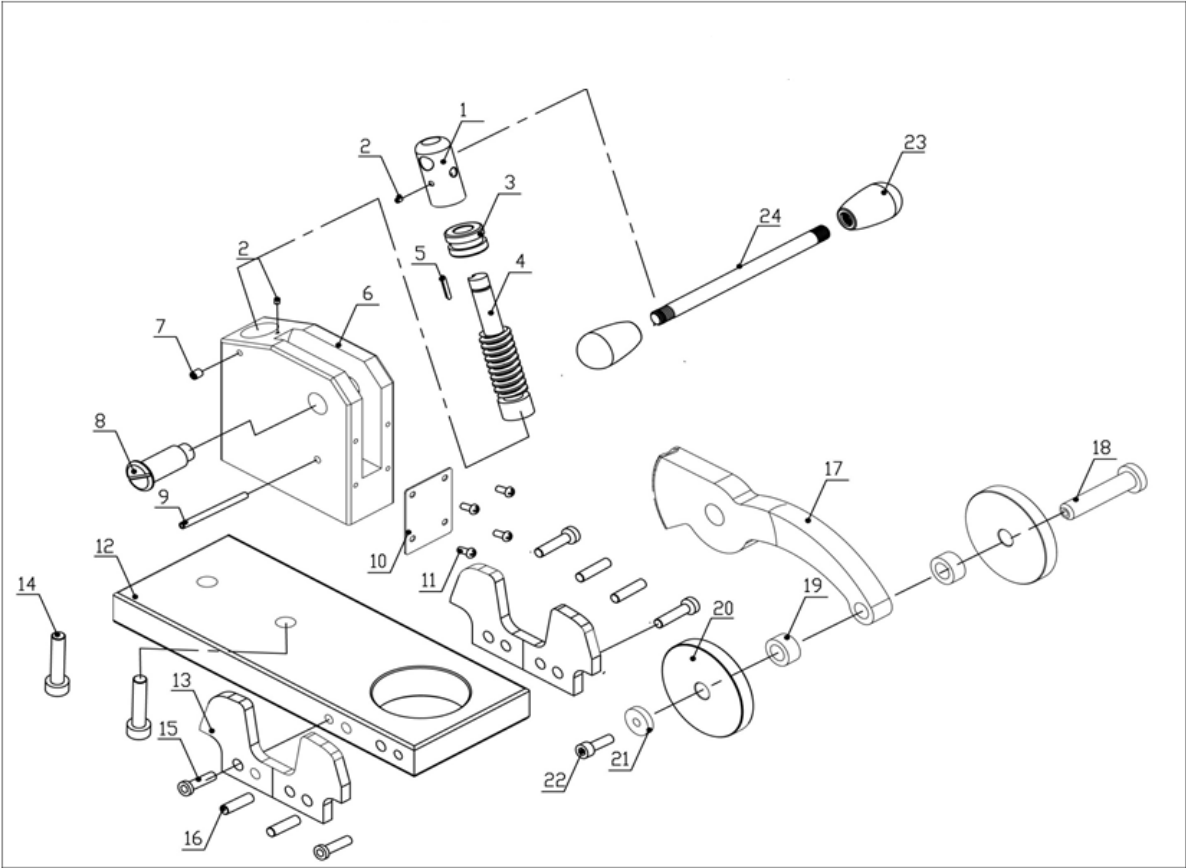

No.	Art.no	Description	Qty
1	020.0508	Worm set	1
2	020.0524	set	2
3	020.0514	Worm bushing	1
4	020.0500	worm	1
5	020.0523	Key	1
6	020.0502	The fixed frame	1
7	020.0525	Set	1
8	020.0513	Connecting bolts	1
9	020.0522	Flexible split pin	1
10	020.0511	Limit piece	1
11	020.0526	Screw	4
12	RAK.002/1	The base	1
13	RAK.002/1	clamp	2
14	020.0520	Inner hexagon bolt	2
15	020.0527	Inner hexagon bolt	4
16	020.0521	The positioning pin	4
17	020.0501	Worm gear radial	1
18	020.0506	Fixed pin	1
19	020.0505	Rocker arm bushing	2
20	020.0504	Rocker arm side panel	2
21	020.0507	The rocker gasket	1
22	020.0074	Screw	1
23	020.0066A	Arm-ball-for-capstan	2
24	020.0066H	Arm-stick-for-capstan	1

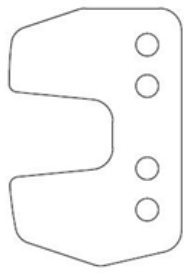

S49

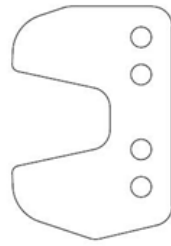

S54

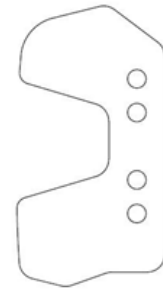

TR68

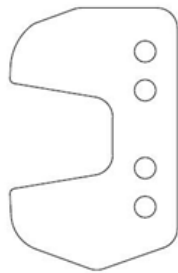

UIC50

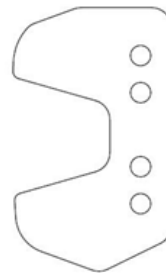

UIC54

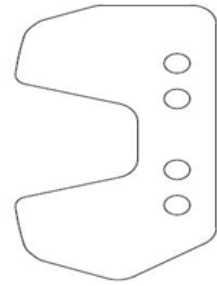

UIC60

Item	Spec.	Art.no
Adapter shape	S49	020.0532
	S54	020.0533
	TR68	020.0534
	UIC50	020.0535
	UIC54	020.0536
	UIC60	020.0537

8.4 Wiring diagram

